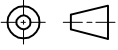

SOURCE DRAWING - FOR REFERENCE ONLY

NOTES:

1. SENSOR WELLS PRESSURE RATING IS 150 PSI.

RELATED DOCUMENTS		3RD ANGLE PROJECTION		THIS DRAWING IS CONFIDENTIAL AND THE PROPERTY OF TURCK INC. USE OF THIS DOCUMENT WITHOUT WRITTEN PERMISSION IS PROHIBITED.		 3000 CAMPUS DRIVE MINNEAPOLIS, MN 55441 1-800-544-7769 (763) 553-7300 (763) 553-0708 fax www.turck.us	
1. 2. 3. 4.				DRFT SWC	DATE 3/28/95	DESCRIPTION TWT-18S-1NPT	
MATERIAL SEE PART NO.		ALL DIMENSIONS DISPLAYED ON THIS DRAWING ARE FOR REFERENCE ONLY		APVD	SCALE NONE	IDENTIFICATION NO. A5056	
FINISH		CONTACT TURCK FOR MORE INFORMATION		UNIT OF MEASUREMENT INCH [MILLIMETER]		REV D	
DO NOT SCALE THIS DRAWING		FILE: A5056		SHEET 1 OF 1			

D	UPDATE NPT CALLOUT	RDS	08/10/22	77856
REV	DESCRIPTION	BY	DATE	ECO NO.